



## EC-轴流风扇

### 200x200x60mm-2

#### 马达可选功能列表 (Available Functions)

1. 马达保护 (Moto protection)

AS

2. 信号输出 (Signal out put)

FG

RD

3. 调速方式 (Speed control mode)

PWM

TC

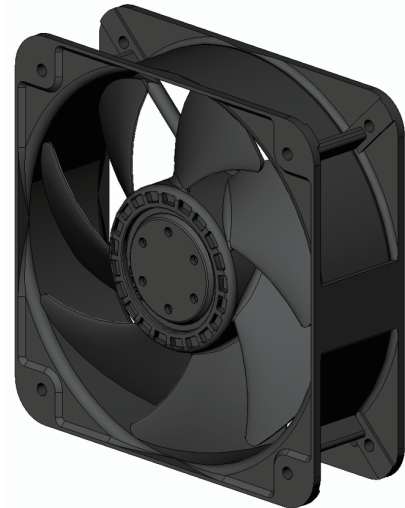

#### 风扇P-Q曲线 / Fan performance curve

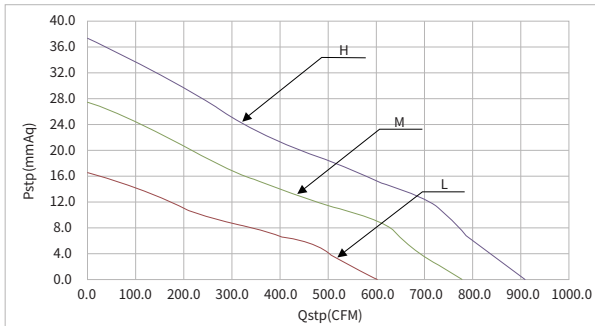

#### 尺寸图 / Dimension drawing

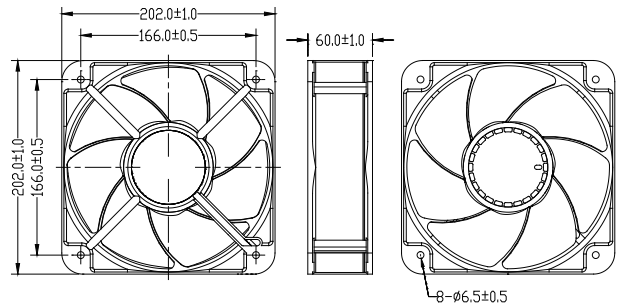

Model		Bearing	Rated Voltage	Voltage Range	Frequency	Power	Speed	Air Flow		Static Pressure		Noise
型号		轴承	额定电压	电压范围	频率	功率	转速	风量		风压		噪音
Part NO.	Function	System	VAC	VAC	Hz	W	RPM	M <sup>3</sup> /min	CFM	mmH <sub>2</sub> O	INH <sub>2</sub> O	dBA
HEB200230HW-2	-A	Ball	110-230	90-260	50/60	146.90	5000	25.63	905.60	36.20	1.43	73.3
HEB200230MW-2	-A			90-260	50/60	93.00	4500	22.05	779.10	27.40	1.08	69.9
HEB200230LW-2	-A			90-260	50/60	44.10	3500	17.15	606.00	16.60	0.65	64.5